

# Flexible Gear Coupling Installation and Maintenance Instructions

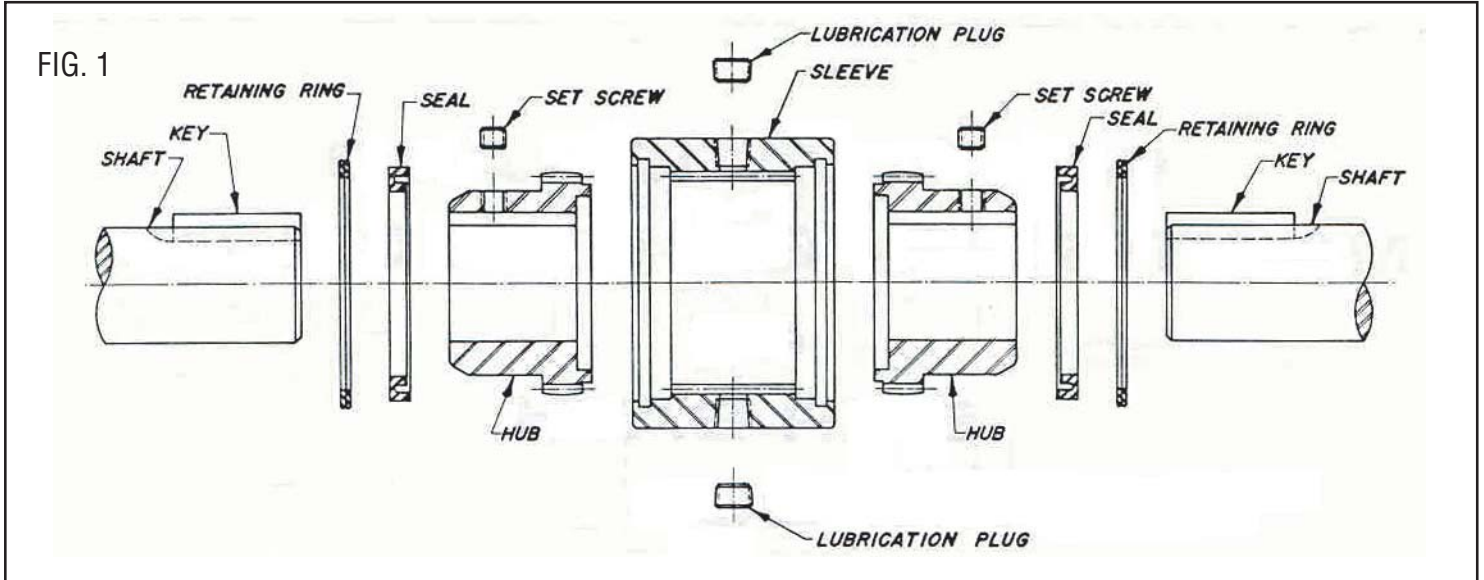
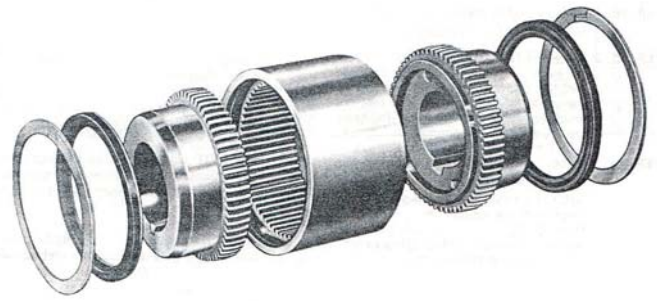

## Follow These Steps to Correctly Install the Flexible Gear Coupling

**Step 1** Be sure that all parts are available and are clean.

**Step 2** Place one (1) snap ring and one (1) seal on each shaft. **IMPORTANT:** Be sure that the groove in the seals face toward the center of the coupling and that the mold mark will be visible after the seals are installed in the coupling.

**Step 3** Install hubs on shaft as shown in FIG. 2 and 3. **NOTE:** Hubs may be installed with shaft flush with the counter bore face (surface 'X' FIG 2) or flush with the aligning face (surface 'Y' FIG 3) as long as the proper gap between hubs is maintained (step 5).

**Shrink Fit:** Shrink fits are recommended for heavy duty or low speed applications. Be sure the key is a snug side fit in the shaft and coupling keyway with clearance on top. Install keys into shafts. Heat hubs uniformly, using hot oil or an oven, to approximately 350° F. Slip hubs on the shafts to the correct location as determined by your installation (see note above).

**Press Fit:** Light press fits may be used for many installations. Unless otherwise specified couplings are furnished with an interference fit.

**Slide Fit:** Slide fits should only be used in low torque, light duty applications (set screws must be firmly tightened).

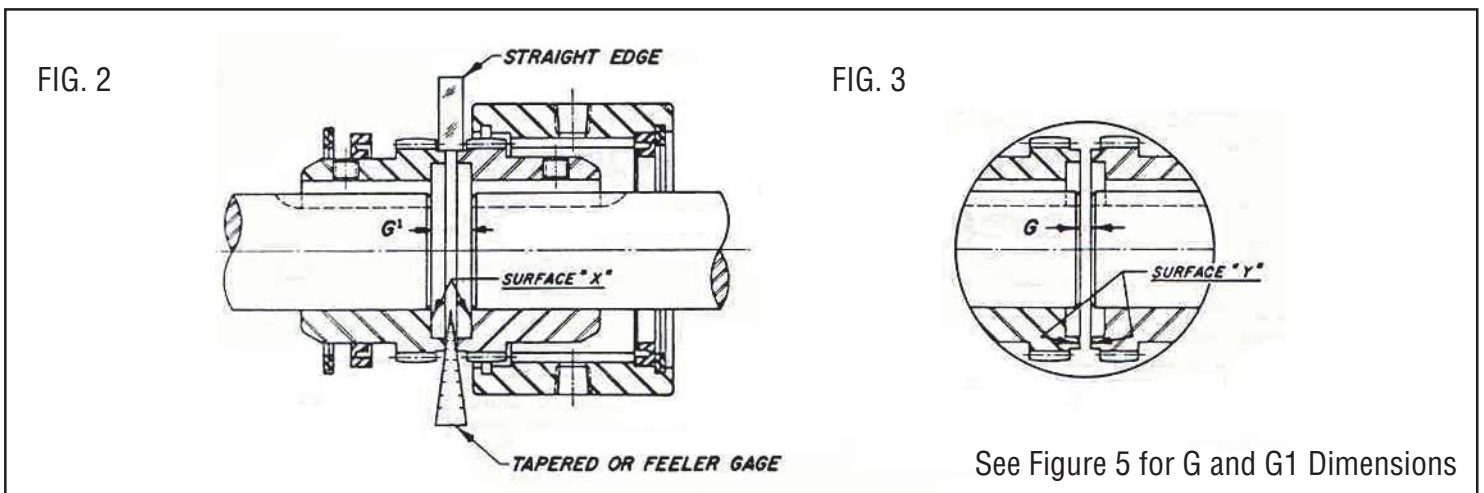

**Step 4** Engage gear teeth and slide sleeve over the hub installed on the longest shaft.

**Step 5** Mount units to be connected in place. Check couplings size (stamped on sleeve) and maintain required spacing G or G1 between hubs as shown on FIG 2 and FIG 3. Check G dimension with a tapered or feeler gauge at 90° intervals. Align hubs using a straight edge at 90° points along aligning diameters (aligning should be as close as possible) by shimming or shifting one or both of the connected units.

**Step 6** Hand pack hub and sleeve teeth with grease, forcing some grease between hub faces G and G1 to provide lubricant reservoir. Lightly coat both seals with grease.

**Step 7** Engage teeth and slide sleeve over hubs to center position. See FIG 4. Press in seals with blunt tool until they are firmly seated against sleeve shoulder. Snap ring grooves should be completely visible. If grooves are not visible, remove sleeve and carefully repeat step 5 and 6.

**Step 8** Insert snap rings in grooves, using a winding motion. **IMPORTANT:** Recheck to insure snap rings are positively seated, and set screws over the keys and the lube plugs are tight.

**Maintenance**

Should your coupling need to be disassembled for an alignment check, remove one snap ring, slide sleeve off hubs. Seal will be forced out of one end during this operation. Clean out old lubricant and inspect seals and gear teeth. Re-assemble starting at step 7.

To re-lubricate without disassembling coupling, remove the lube plugs and position lube holes at 45° to horizontal. Force grease into top hole until clean grease flows out of opposite hole.

Re-install plugs.

**CAUTION:** Always wear safety glasses and use proper tools when working on machinery.

MANUFACTURER	LUBRICANT
American Oil Co.	Rykon 1 EP
Atlantic Refining Co.	Lubricant #17 & #52
Brook Oil Co.	Leadolene #375 Light
Cities Service Oil Co.	Trojan A-1
Continental Oil Co.	Conoco Super-Lube
Fiske Bros. Refining Co.	Lubriplate 630 AA
Gulf Oil Co.	Gulfcrown EP-O
Humble Oil & Refining Co.	Nebula EP-O
Keystone	#15 EP XXLT
Mobil Oil Co.	Mobilux EP-O
Phillips Petroleum Co.	Philube #1 & #2

This list is not meant to limit the users' selection of lubricants. Other lubricants of comparable quality may also be used for normal operating conditions. For high speeds, and extreme temperatures, consult the factory for lubrication recommendations.

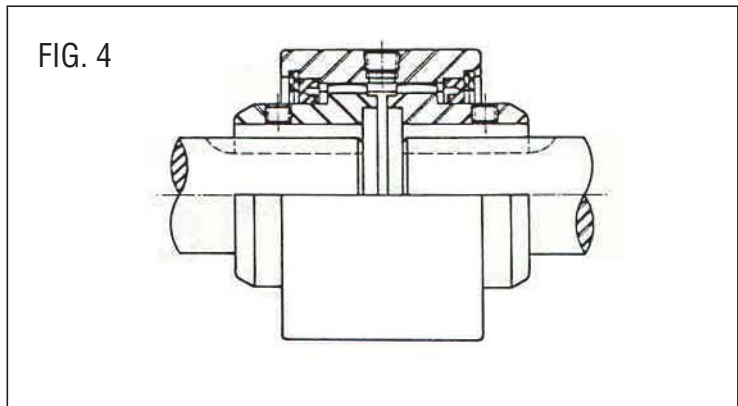

FIG. 5

Size	Grease Capacity		Approx. Wt. Lbs. R. Bore	Distance Between Shafts*	
	Weight	Volume		G DIM FIG 3	G1 DIM FIG 3
C 7/8	1 oz.	1/8 Pt.	5	1/8	3/8
C 1 1/2	1 1/2 oz.	1/3 Pt.	8	1/8	1/2

\* May be any dimension between G and G1

MANUFACTURER	LUBRICANT
Pure Oil Co.	Poco HT-EP-1
Pennzoil Co.	TTM Multi-Purpose
Quaker State Oil Co.	EXPP-2
Shell Oil Co.	Alvania EP-2
Sinclair Refining Co.	Litholine Multi-Purpose
Sun Oil Co.	Prestige #741 EP
Standard Oil of California	Calol Industrial (medium)
Standard Oil of Ohio	Sohitran 2
Texaco Inc.	Marfax #1
Tidewater Oil Co.	Veedol Alitho 20