

ACTIONJAC™ CYLINDERS

ActionJac™ Electric Cylinders are ruggedly designed and produced in standard models with thrust capacities from 500 lbs. to 40,000 lbs. Electric Cylinders are intended for use in industrial environments and feature ground and hard chrome plated actuator tubes with epoxy paint on exterior surfaces. Electric Cylinders can be supplied for outdoor applications.

These cylinders may be used individually or in multiple arrangements. Each ActionJac™ Electric Cylinder is built to specification.

DD WORM GEAR ELECTRIC CYLINDERS

DD or "Direct Drive" worm gear driven Electric Cylinders incorporate an alloy steel worm which drives a high strength bronze worm gear (drive sleeve). The worm shaft is supported on anti-friction tapered roller bearings with external seals provided to prevent loss of

lubrication (sealed radial bearings on the Series 5 and Series 10 units). The drive sleeve is supported on anti-friction tapered roller or ball thrust bearings. The jack housing is made of ductile iron and proportioned to support the rated capacity of the unit.

In operation, the drive sleeve rotates the lift shaft causing the actuator tube to extend and retract from the housing tube. Actuator tube must be secured to prevent rotation.

Motors can be mounted to DD Electric Cylinders by using available standard motor mounts. For use in multiple cylinder arrangements, DD Electric Cylinders can be supplied without motor mounts.

The DD Electric Cylinders are available in Acme Screw or Ball Screw versions and have a variety of worm gear ratios resulting in a wide range of speeds and thrust capacities. (SEE FIG. 1)

RAD WORM GEAR ELECTRIC CYLINDERS

RAD worm gear driven Electric Cylinders incorporate the features of the DD with a second stage of gear reduction. This secondary worm gear reduction of the RAD Electric Cylinders provides higher thrust at lower speeds. The reducer and motor can be mounted in eight possible positions for maximum flexibility.

RAD Electric Cylinders are available in Acme Screw or Ball Screw versions. (SEE FIG. 1)

ILA ELECTRIC CYLINDER

The ILA ActionJac™ In-Line Electric Cylinders are the newest member of the Electric Cylinder family. These cylinders are designed to have a motor or gear reducer directly coupled to the lift shaft. This provides for fast, precise operation and/or higher duty cycles.

ILA Electric Cylinders feature standard trunnion pin mounting and are easily adapted for use with

FIG.1

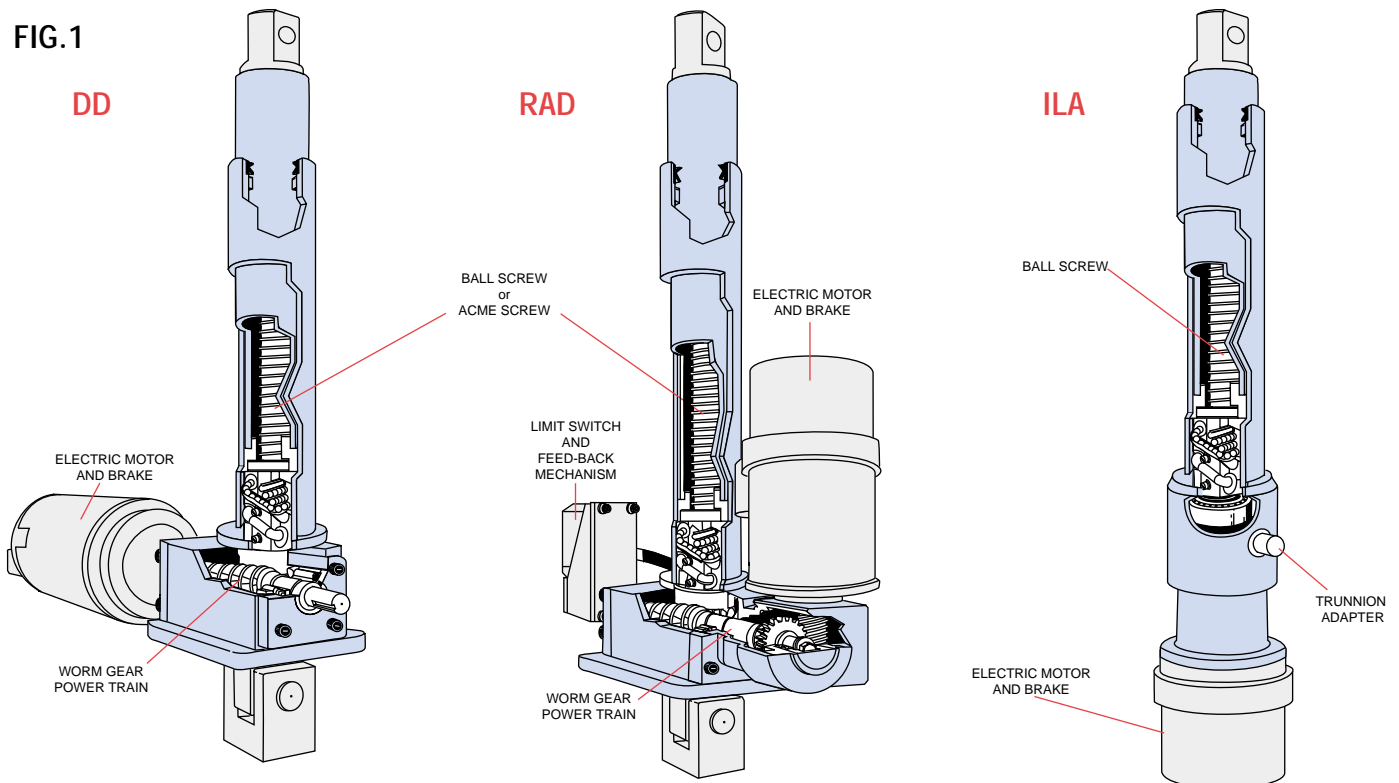

servo motors and planetary gear reducers. **(SEE FIG. 1)**

In line Electric Cylinders are Ball Screw actuated. Configurations are available with keyed and un-keyed actuator tubes.

ACCESSORIES

Accessories such as motors, motor mounts, encoders, hand wheels, counters, couplings, miter gear boxes, boots, limit switches, clevises, clevis pins and clevis brackets are available. **(SEE FIG. 2)**

NOTE: Units are not to be used for personnel support or movement.

GLOSSARY & TERMS

CYLINDER CONFIGURATIONS

ActionJac™ Electric Cylinders can be manufactured into a number of different configurations. These configurations include clevis, trunnion or flange mounts, position feedback devices and a variety of motor mounts.

BACKLASH

Backlash (lash) is the relative axial movement between a screw and nut without rotation of the screw or nut. Backlash in cylinders occurs wherever reversible load conditions exist. Backlash is less than .015" for all but the largest cylinder models.

Ball Screw Cylinders can be factory adjusted to reduce backlash at the lift shaft by selecting bearing ball size in the ball nut. This selective fit technique can be used to achieve a minimal lash between the ball nut and ball screw of .003" to .005". Precision ball screws with preloaded nuts can be supplied when less than .001" backlash is required.

REACTION TORQUE

When an electric cylinder is used to move a load, the actuator tube must be secured to prevent rotation. The reaction torque required to prevent rotation varies with lead of the screw and the amount of load put on the cylinder. See product specification sheets for rod reaction torque.

Prior to installation, the actuator tube can rotate freely in or out of the cylinder without movement of the input worm. This ability to rotate aids installation but prevents the optional rotary limit switch from being factory preset for end of travel positions.

Rod-Type Limit Switches prevent tube from freely rotating but are not intended to absorb rod reaction torque.

TRAVEL LENGTH

Electric Cylinders are not pre-assembled or stocked with standard length screws. Each cylinder is made to order based on travel length.

Cylinders can be built with non-standard lead screws to change the cylinder operating speed or with ground or preloaded screws if required by the application. Contact Nook Industries for availability of special units.

FIG. 2

