

2D/3D CAD Drawings
at nookindustries.com

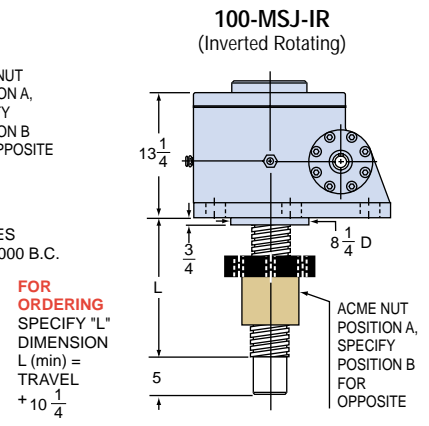
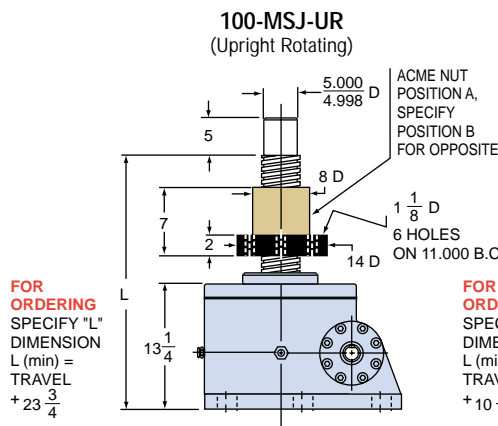

TOP PLATE (optional): B9000-00-21

CLEVIS END (optional): B9001-00-21

ROTARY LIMIT SWITCH
see page 254-

100-MSJ STANDARD SCREW

SCREW: 6 - 1 1/2
 ROOT DIAMETER: 5.254
 DRAG TORQUE: 205 IN.-LB.
 START TORQUE: 2 x Running Torque
 WEIGHT (Approx. in Pounds)
 "0" TRAVEL: 975
 PER INCH TRAVEL: 8.5
 GREASE: 16.0

RATIO	TURNS OF WORM PER INCH TRAVEL	TORQUE TO RAISE ONE LB.		MAX. HP	MAX. WORM SPEED AT RATED LOAD		MAX. LOAD AT 1750 RPM	
		NON-KEYED	KEYED		NON-KEYED	KEYED	NON-KEYED	KEYED
10 ³ / ₁₆ :1	16	.0665 in.-lbs.	—	32	153 rpm	—	17330 lbs.	—
32:1	48	.0377 in.-lbs.	—	12 ¹ / ₂	106 rpm	—	11941 lbs.	—

LIFTING SCREW OR NUT MUST BE SECURED TO PREVENT ROTATION FOR NON-KEYED UNITS.
CAUTION! JACK MAY BE SELF-LOWERING IN SOME OPERATING CONDITIONS.